

## EOLP-1680-14XXN series

**SFP+ Single-Mode for DWDM Application**  
**Duplex SFP+ Transceiver**  
**Digital Diagnostic Function**  
**RoHS6 Compliant**

### Features

- ◆ Available in all C-Band Wavelengths on the 100GHz DWDM ITU Grid
- ◆ Temperature-Stabilized DWDM EML Transmitter
- ◆ Duplex LC Connector
- ◆ Power Dissipation < 1.5W
- ◆ Dispersion tolerance from -300ps/nm to 800ps/nm
- ◆ Hot-Pluggable SFP+ Footprint
- ◆ Compliant with SFF-8431 MSA
- ◆ Compliant with SFF-8432 MSA
- ◆ Operating Case Temperature

Standard: 0°C to 70°C

Industrial: -40°C ~ 85°C



### Applications

- ◆ 8G FC
- ◆ OBSAI rates 6.144 Gb/s, 3.072 Gb/s, 1.536 Gb/s, 0.768Gb/s
- ◆ CPRI rates 7.373Gb/s, 6.144 Gb/s, 4.915 Gb/s, 2.458 Gb/s, 1.229 Gb/s, 0.614Gb/s
- ◆ Other optical links

### Ordering Information

Part No.	Data Rate	Laser	Power budget	CDR	Case Temp.
EOLP-1680-14XXN <sup>*(note1)</sup>	0.614Gbps to 8.5Gbps	DWDM EML	14dB	NO	Standard
EOLP-1680-14XXIN <sup>*(note1)</sup>	0.614Gbps to 8.5Gbps	DWDM EML	14dB	NO	Industrial

Note1: XX refers to DWDM Wavelength channel as ITU-T specified, please refer the following table for detailed center wavelength information.

XX- Channel refers to the following table:

Channel (X) <sup>*(note2)</sup>	Part NO.	Frequency (THz)	Center Wavelength (nm)
15	EOLP-1680-1415N	191.5	1565.50
16	EOLP-1680-1416N	191.6	1564.68
17	EOLP-1680-1417N	191.7	1563.86
18	EOLP-1680-1418N	191.8	1563.05
19	EOLP-1680-1419N	191.9	1562.23
20	EOLP-1680-1420N	192.0	1561.42
21	EOLP-1680-1421N	192.1	1560.61
22	EOLP-1680-1422N	192.2	1559.79
23	EOLP-1680-1423N	192.3	1558.98
24	EOLP-1680-1424N	192.4	1558.17
25	EOLP-1680-1425N	192.5	1557.36
26	EOLP-1680-1426N	192.6	1556.55
27	EOLP-1680-1427N	192.7	1555.75
28	EOLP-1680-1428N	192.8	1554.94
29	EOLP-1680-1429N	192.9	1554.13
30	EOLP-1680-1430N	193.0	1553.33
31	EOLP-1680-1431N	193.1	1552.52
32	EOLP-1680-1432N	193.2	1551.72
33	EOLP-1680-1433N	193.3	1550.92
34	EOLP-1680-1434N	193.4	1550.12
35	EOLP-1680-1435N	193.5	1549.32
36	EOLP-1680-1436N	193.6	1548.51
37	EOLP-1680-1437N	193.7	1547.72
38	EOLP-1680-1438N	193.8	1546.92
39	EOLP-1680-1439N	193.9	1546.12
40	EOLP-1680-1440N	194.0	1545.32
41	EOLP-1680-1441N	194.1	1544.53
42	EOLP-1680-1442N	194.2	1543.73
43	EOLP-1680-1443N	194.3	1542.94
44	EOLP-1680-1444N	194.4	1542.14
45	EOLP-1680-1445N	194.5	1541.35
46	EOLP-1680-1446N	194.6	1540.56
47	EOLP-1680-1447N	194.7	1539.77
48	EOLP-1680-1448N	194.8	1538.98
49	EOLP-1680-1449N	194.9	1538.19
50	EOLP-1680-1450N	195.0	1537.40
51	EOLP-1680-1451N	195.1	1536.61
52	EOLP-1680-1452N	195.2	1535.82
53	EOLP-1680-1453N	195.3	1535.04
54	EOLP-1680-1454N	195.4	1534.25

55	EOLP-1680-1455N	195.5	1533.47
56	EOLP-1680-1456N	195.6	1532.68
57	EOLP-1680-1457N	195.7	1531.90
58	EOLP-1680-1458N	195.8	1531.12
59	EOLP-1680-1459N	195.9	1530.33
60	EOLP-1680-1460N	196.0	1529.55
61	EOLP-1680-1461N	196.1	1528.77

\*Note2: Please contact with EOPTOLINK for the channel availability.

### Regulatory Compliance\*

Product Certificate	Certificate Number	Applicable Standard
TUV	R50135086	EN 60950-1:2006+A11+A1+A12
		EN 60825-1:2007
		EN 60825-2:2004+A1+A2
UL	E317337	UL 60950-1
		CSA C22.2 No. 60950-1-07
EMC CE	AE 50285865 0001	EN 55022:2010
		EN 55024:2010
CB	JPTUV-049251	IEC 60825-1
		IEC 60950-1
FCC	WTF14F0514437E	47 CFR PART 15 OCT., 2013
FDA	1331340-000	CDRH 1040.10
ROHS	RHS01G006464	2011/65/EU

\*The above certificate number updated to June 2014, because some certificate will be updated every year, such as FCC, FDA and ROHS. For the latest certification information, please check with Eoptolink.

### Product Description

The EOLP-1680-14XX series single mode transceiver is small form factor pluggable module for duplex optical data communications. This module is designed for single mode fiber and operates at a nominal DWDM wavelength from 1528nm to 1566nm as specified by the ITU-T. It is designed to deploy in the DWDM networking equipment in metropolitan access and core networks.

It is with the SFP+ 20-pin connector to allow hot plug capability. The transmitter section uses a DWDM EML laser and is a class 1 laser compliant according to International Safety Standard IEC-60825. The receiver section uses a PIN detector and a limiting post-amplifier IC.

The EOLP-1680-14XX series are designed to be compliant with SFP+ Multi-Source Agreement (MSA) Specification SFF-8431.

## Absolute Maximum Ratings<sup>\*(note3)</sup>

Parameter	Symbol	Min.	Max.	Unit
Storage Temperature	Ts	-40	+85	°C
Supply Voltage	Vcc	-0.5	3.6	V
Operating Relative Humidity		-	95	%

\* Note3: Exceeding any one of these values may destroy the device immediately.

## Recommended Operating Conditions

Parameter	Symbol	Min.	Typical	Max.	Unit
Operating Case Temperature	T <sub>c</sub>	Standard	0	+70	°C
		Industrial	-40	85	°C
Power Supply Voltage	Vcc	3.15	3.3	3.45	V
Power Supply Current	Icc		350	455	mA
Date Rate	EOLP-1680-14XXN	0.614		8.5	Gbps

## Performance Specifications – Electrical

Parameter	Symbol	Min.	Typ.	Max	Unit	Notes
<b>Transmitter</b>						
CML Inputs(Differential)	Vin	250		1000	mVpp	AC coupled input <sup>*(note6)</sup>
Input Impedance (Differential)	Zin	85	100	115	ohm	Rin > 100 kohm @ DC
TX_Dis	Disable	2		Vcc+0.3	V	
	Enable	0		0.8		
TX_FAULT	Fault	2		Vcc+0.3	V	
	Normal	0		0.5		
<b>Receiver</b>						
CML Outputs (Differential)	Vout	350		700	mVpp	AC coupled output <sup>*(note6)</sup>
Output Impedance (Differential)	Zout	85	100	115	ohm	
RX_LOS	LOS	2		Vcc+0.3	V	
	Normal	0		0.8	V	
MOD_DEF ( 0:2 )	VoH	2.5			V	With Serial ID
	VoL	0		0.5	V	

## Performance Specifications – Optical

Parameter	Symbol	Min.	Typical	Max.	Unit
Data Rate		0.614		8.5	Gbps
<b>Transmitter</b>					
Center Wavelength Spacing			100		GHz
			0.8		nm
Side Mode Suppression Ratio	SMSR	30			dB
Average Output Power <sup>*(note4)</sup>	Pout	-1		4	dBm
Average Launch Power (Tx: OFF)	Poff			-30	dBm
Extinction Ratio, EOLP-1680-14XXN	ER	3.5			dB
Transmitter Dispersion Penalty @800ps/nm	TDP			2	dB
P <sub>out</sub> @TX Disable Asserted	Pout			-45	dBm
Relative Intensity Noise	RIN			-128	dB/Hz
TX Jitter	TXj	Per 802.3ae requirements			
<b>Receiver</b>					
Receiver Sensitivity <sup>*(note5)</sup>	Pmin			-15	dBm
Receiver Overload	Pmax	-1			dBm
LOS De-Assert	LOSD			-17	dBm
LOS Assert	LOSA	-29			dBm
LOS Hysteresis		1			dB

Note4: Output is coupled into a 9/125µm single-mode fiber.

Note5: Minimum average optical power measured at the BER less than 1E-12. The measure pattern is PRBS 2<sup>31</sup>-1.

Note6: CML logic, internally AC coupled.

## SFP+ Transceiver Electrical Pad Layout

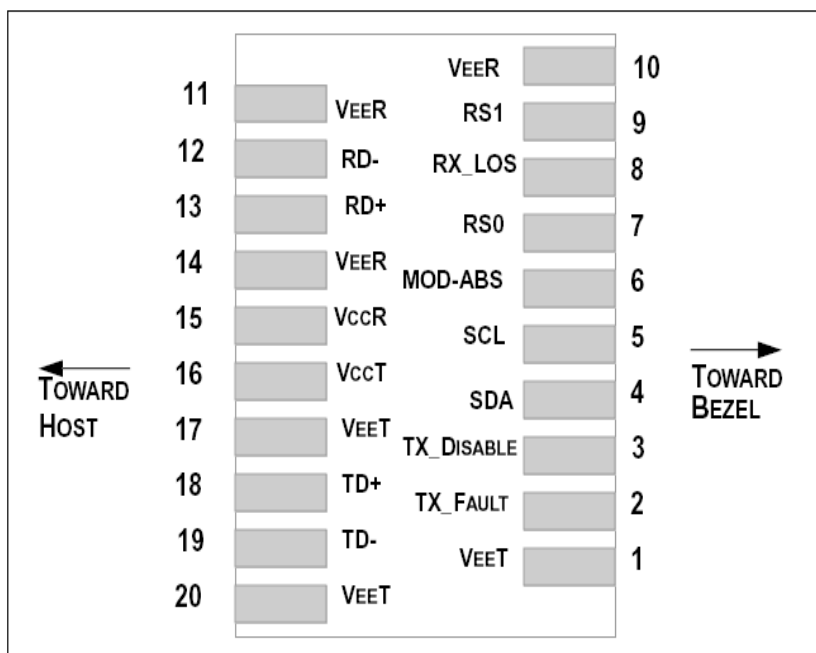

## Pin Function Definition

Pin Num.	Name	FUNCTION	Plug Seq.	Notes
1	VeeT	Transmitter Ground	1	Note 5
2	TX Fault	Transmitter Fault Indication	3	Note 1
3	TX Disable	Transmitter Disable	3	Note 2, Module disables on high or open
4	SDA	Module Definition 2	3	Note 3, Data line for Serial ID.
5	SCL	Module Definition 1	3	Note 3, Clock line for Serial ID.
6	MOD-ABS	Module Definition 0	3	Note 3
7	RS0	RX Rate Select (LVTTTL).	3	Rate Select 0, optionally controls SFP+ module receiver. This pin is pulled low to VeeT with a >30K resistor
8	LOS	Loss of Signal	3	Note 4
9	RS1	TX Rate Select (LVTTTL).	1	Rate Select 1, optionally controls SFP+ module transmitter. This pin is pulled low to VeeT with a >30K resistor.
10	VeeR	Receiver Ground	1	Note 5
11	VeeR	Receiver Ground	1	Note 5
12	RD-	Inv. Received Data Out	3	Note 6
13	RD+	Received Data Out	3	Note 7
14	VeeR	Receiver Ground	1	Note 5
15	VccR	Receiver Power	2	3.3 ± 5%, Note 7
16	VccT	Transmitter Power	2	3.3 ± 5%, Note 7
17	VeeT	Transmitter Ground	1	Note 5
18	TD+	Transmit Data In	3	Note 8
19	TD-	Inv. Transmit Data In	3	Note 8
20	VeeT	Transmitter Ground	1	Note 5

### Notes:

1) TX Fault is an open collector/drain output, which should be pulled up with a 4.7K – 10KΩ resistor on the host board. Pull up voltage between 2.0V and VccT, R+0.3V. When high, output indicates a laser fault of some kind. Low indicates normal operation. In the low state, the output will be pulled to < 0.8V.

2) TX disable is an input that is used to shut down the transmitter optical output. It is pulled up within the module with a 4.7 – 10 KΩ resistor. Its states are:

Low (0 – 0.8V): Transmitter on

(>0.8, < 2.0V): Undefined

High (2.0 – 3.465V): Transmitter Disabled

Open: Transmitter Disabled

- 3) Module absent, connected to VEET or VEER in the module.
- 4) LOS (Loss of Signal) is an open collector/drain output, which should be pulled up with a 4.7K – 10KΩ resistor. Pull up voltage between 2.0V and VccT, R+0.3V. When high, this output indicates the received optical power is below the worst-case receiver sensitivity (as defined by the standard in use). Low indicates normal operation. In the low state, the output will be pulled to < 0.8V.
- 5) VeeR and VeeT may be internally connected within the SFP+ module.
- 6) RD-/+ : These are the differential receiver outputs. They are AC coupled 100Ω differential lines which should be terminated with 100Ω (differential) at the user SERDES. The AC coupling is done inside the module and is thus not required on the host board.
- 7) VccR and VccT are the receiver and transmitter power supplies. They are defined as 3.3V ±5% at the SFP+ connector pin. Maximum supply current is 300mA. Inductors with DC resistance of less than 1 ohm should be used in order to maintain the required voltage at the SFP+ input pin with 3.3V supply voltage. When the recommended supply-filtering network is used, hot plugging of the SFP+ transceiver module will result in an inrush current of no more than 30mA greater than the steady state value. VccR and VccT may be internally connected within the SFP+ transceiver module.
- 8) TD-/+ : These are the differential transmitter inputs. They are AC-coupled, differential lines with 100Ω differential termination inside the module. The AC coupling is done inside the module and is thus not required on the host board.

### EEPROM

The optical transceiver contains an EEPROM. It provides access to sophisticated identification information that describes the transceiver's capabilities, standard interfaces, manufacturer, and other information.

The serial interface uses the 2-wire serial CMOS EEPROM protocol. When the serial protocol is activated, the host generates the serial clock signal (SCL, Mod Def 1). The positive edge clocks data into those segments of the EEPROM that are not writing protected within the SFP+ transceiver. The negative edge clocks data from the SFP+ transceiver. The serial data signal (SDA, Mod Def 2) is bi-directional for serial data transfer. The host uses SDA in conjunction with SCL to mark the start and end of serial protocol activation. The memories are organized as a series of 8-bit data words that can be addressed individually or sequentially.

The module provides diagnostic information about the present operating conditions. The transceiver generates this diagnostic data by digitization of internal analog signals. Alarm/warning threshold data is written during device manufacture. TEC current monitoring, laser temperature monitoring, received power monitoring, transmitted power monitoring, bias current monitoring, supply voltage monitoring and transceiver temperature monitoring all are implemented. The diagnostic data are internal calibration and stored in memory locations 96 – 109 at wire serial bus address A2h. The transceiver memory map specific data field defines as

following.

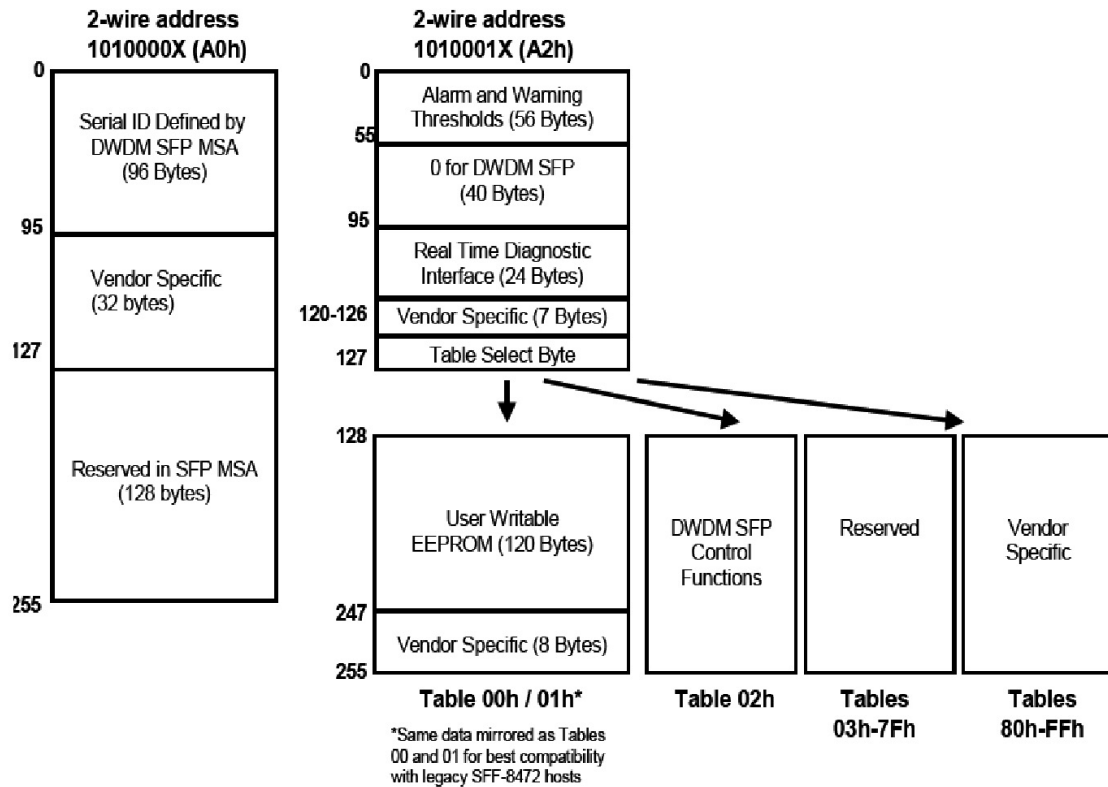

## Recommend Circuit Schematic

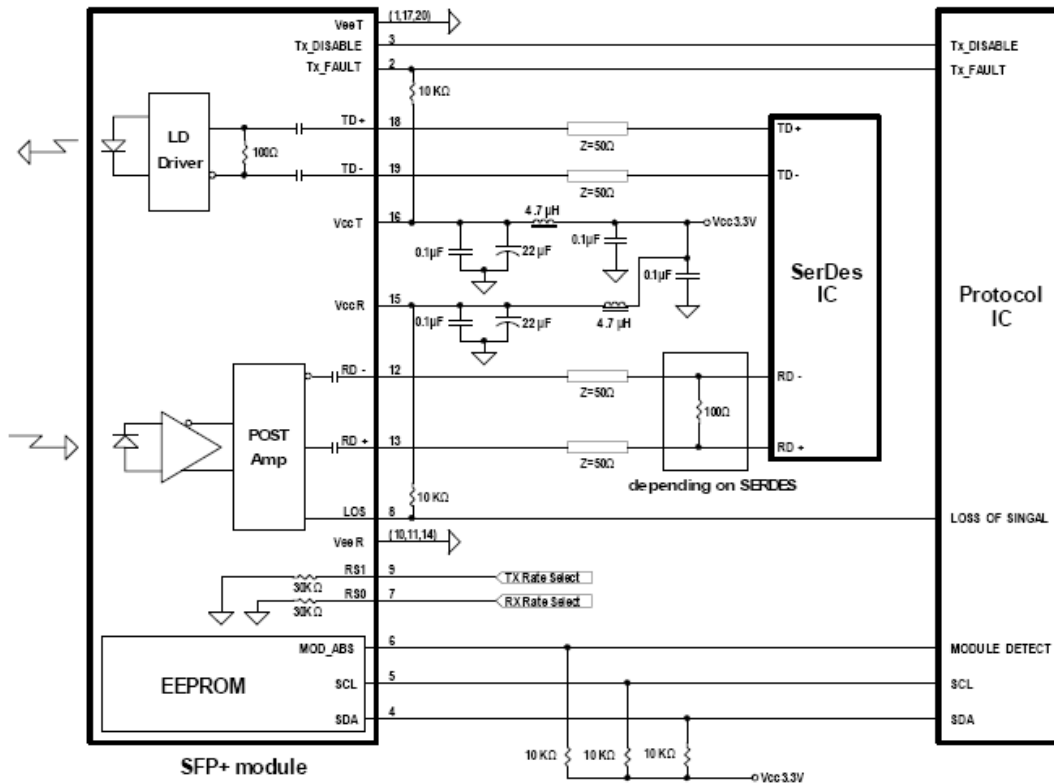



## Mechanical Specifications

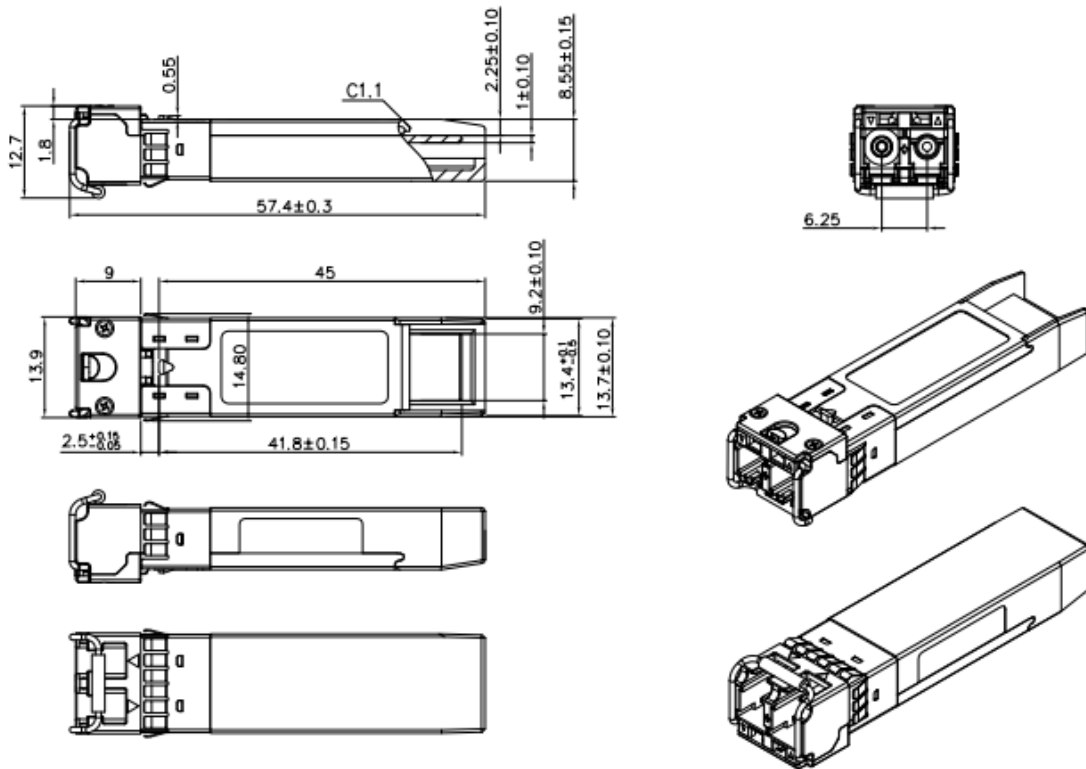

Unremarked tolerances  $\pm 0.2\text{mm}$

## Laser Emission



## Obtaining Document

You can visit our website:

<http://www.eoptolink.com>

Or contact Eoptolink Technology Inc., Ltd. Listed at the end of the documentation to get the latest documents.

### Revision History

Revision	Initiated	Reviewed	Approved	Revision History	Release Date
V1.a	Airon	Kelly, Frank, Torres, Fing, Eason, JP, Abby		New Released.	Jan 22, 2014
V1.b	Angela	Kelly/Vina		Update the regulatory compliance and mechanical spec,	Feb 03, 2015
V1.c	Angela	Kelly/Vina		Add industrial temperature and CPRI/OBSAI application. Update the 2D drawing.	July 15, 2015

### Notice:

Eoptolink reserves the right to make changes to or discontinue any optical link product or service identified in this publication, without notice, in order to improve design and/or performance. Applications that are described herein for any of the optical link products are for illustrative purposes only. Eoptolink makes no representation or warranty that such applications will be suitable for the specified use without further testing or modification.

### Contact:

Add: Floor 5, Building 2, No. 21 Gaopeng Avenue, High-Tech District, CHENGDU, SICHUAN  
610041 P.R. CHINA

Tel: (+86) 028-85122709 ext 816 & 809

Fax: (+86) 028-85121912

Postal: 610041

E-mail: [sales@eoptolink.com](mailto:sales@eoptolink.com)

<http://www.eoptolink.com>