

EOLP-1680-23XN

CWDM SFP+ Single-Mode for 8G FC
Duplex SFP+ Transceiver
RoHS6 Compliant

Features

- ◆ Supports up to 8.5Gb/s Bit Rates
- ◆ Hot-Pluggable SFP+ Footprint
- ◆ 8-Wavelengths CWDM EML Transmitter from 1470nm to 1610nm, with step 20nm
- ◆ With High Sensitivity APD
- ◆ 23dB Power Budget
- ◆ Duplex LC connector
- ◆ Power Dissipation < 1.8W
- ◆ Dispersion tolerance 1600ps/nm
- ◆ Case Operation Temperature Range
- ◆ Standard: 0°C to 70°C
- ◆ Industrial: -40°C~85°C
- ◆ Compliant with SFP+ MSA Specification SFF-8431
- ◆ Build-in Digital Diagnostic Functions
Compliant with SFF-8472 MSA Specification



Applications

- ◆ 8 X Fiber Channel
- ◆ OBSAI rates 6.144 Gb/s, 3.072 Gb/s, 1.536 Gb/s, 0.768Gb/s
- ◆ CPRI rates 7.373Gb/s, 6.144 Gb/s, 4.915 Gb/s, 2.458 Gb/s, 1.229 Gb/s, 0.614Gb/s
- ◆ Other optical links

Ordering information

Part No.	Data Rate	Laser	Fiber	Power Budget	Interface	Case Temp.	DDMI
EOLP-1696-23X-N ^{*(note1)}	0.614Gbps to 8.5Gbps	CWDM EML	SMF	23dB	LC	Standard	YES
EOLP-1696-23X-IN ^{*(note1)}	0.614Gbps to 8.5Gbps	CWDM EML	SMF	23dB	LC	Industrial	YES

Note1: X refers to CWDM Wavelength range 1470nm to 1610nm, X=K~R, denotes 1470~1610nm.

CWDM* Wavelength

Band	Nomenclature	Wavelength(nm)		
		Min.	Typ.	Max.
S-band Short Wavelength	K	1464	1470	1477.5
	L	1484	1490	1497.5
	M	1504	1510	1517.5
	N	1524	1530	1537.5
C-band Conventional	O	1544	1550	1557.5
L-band Long Wavelength	P	1564	1570	1577.5
	Q	1584	1590	1597.5
	R	1604	1610	1617.5

CWDM*: 8 Wavelengths from 1470nm to 1610nm, each step 20nm.

Regulatory Compliance*

Product Certificate	Certificate Number	Applicable Standard
TUV	R50135086	EN 60950-1:2006+A11+A1+A12
		EN 60825-1:2007
		EN 60825-2:2004+A1+A2
UL	E317337	UL 60950-1
		CSA C22.2 No. 60950-1-07
EMC CE	AE 50285865 0001	EN 55022:2010
		EN 55024:2010
CB	JPTUV-049251	IEC 60825-1
		IEC 60950-1
FCC	WTF14F0514437E	47 CFR PART 15 OCT., 2013
FDA	1331340-000	CDRH 1040.10
ROHS	RHS01G006464	2011/65/EU

*The above certificate number updated to June 2014, because some certificate will be updated every year, such as FCC, FDA and ROHS. For the latest certification information, please check with Eoptolink.

Product Description

The EOLP-1680-XX series optical transceiver is designed for fiber communications application such as 8.5G application (8G Fiber Channel), which fully compliant with the specification of SFP+ MSA SFF-8431.

This module is designed for single mode fiber and operates at a nominal wavelength of CWDM wavelength. There are eight center wavelengths available from 1470nm to 1610nm, with each step 20nm. A guaranteed optical link budget of 23 dB is offered.

The module is with the SFP+ connector to allow hot plug capability. Only single 3.3V power supply is needed. The optical output can be disabled by LVTTTL logic high-level input of TX_DIS. Loss of signal (RX_LOS) output is provided to indicate the loss of an input optical signal of receiver.

This module provides digital diagnostic functions via a 2-wire serial interface as defined by the SFF-8472 specification.

Absolute Maximum Ratings

Parameter	Symbol	Min	Typical	Max	Unit	Note
Maximum Supply Voltage 1	V _{cc}	-0.5		4.0	V	
Storage Temperature	T _s	-40		85	°C	

Recommend Operating Condition

Parameter	Symbol	Min	Typical	Max	Units	Note
Case Operating Temperature	T _c	Standard	0		+70	°C
		Industrial	-40		85	°C
Supply Voltage	V _{cc}	3.13	3.3	3.45	V	
Supply Current	I _{cc}			520	mA	
Data Rate		0.614		8.5	Gbps	

Electrical Characteristics

Parameter	Symbol	Min.	Typ.	Max	Unit	Notes
Transmitter						
CML Inputs(Differential)	V _{in}	180		1000	mVpp	1
Input Impedance (Differential)	Z _{in}	85	100	115	ohm	
TX_DISABLE Input Voltage - High		2		V _{cc} +0.3	V	
TX_DISABLE Input Voltage - Low		0		0.8	V	
TX_FAULT Output Voltage - High		2		V _{cc} +0.3	V	
TX_FAULT Output Voltage - Low		0		0.8	V	
Receiver						
CML Outputs (Differential)	V _{out}	350		700	mVpp	1
Output Impedance (Differential)	Z _{out}	85	100	115	ohm	
RX_LOS Output Voltage - High		2		V _{cc} +0.3	V	

RX_LOS Output Voltage - Low		0		0.8	V	
MOD_DEF (0:2)	VoH	2.5			V	2
	VoL	0		0.5	V	

Notes:

1. After internal AC coupling.
2. Reference the SFF-8472 MSA.

Optical Characteristics

Parameter	Symbol	Min	Typical	Max	Unit	Note
Transmitter						
Output Opt. Pwr: 9/125 SMF	P _{out}	0		+4	dBm	1
Optical Extinction Ratio	ER	3.5			dB	
Optical Wavelength	λ	$\lambda_c - 6$	λ_c	$\lambda_c + 7.5$	nm	2
-20dB Spectrum Width	$\Delta\lambda$			1	nm	
Side Mode Suppression Ratio	SMSR	30			dB	
Average Launch Power of OFF Transmitter	P _{OFF}			-30	dBm	
Transmitter Dispersion Penalty	TDP			3.5	dB	
TX Jitter	TX _j	Per 802.3ae requirements				
Relative Intensity Noise	RIN			-128	dB/Hz	
Receiver						
Receiver Sensitivity	P _{min}			-23	dBm	3
Input Overload	P _{max}	-6			dBm	
Optical Center Wavelength	λ	1260		1620	nm	
Receiver Reflectance	R _{rf}			-12	dB	
LOS De-Assert	LOS _D			-24	dBm	
LOS Assert	LOS _A	-37			dBm	
LOS Hysteresis		1			dB	

Notes:

1. Output power is coupled into a 9/125 μ m SMF.
2. ITU-T G.694.2 CWDM wavelength from 1470nm to 1610nm, each step 20nm.
3. Average received power; BER less than 1E-12 and PRBS 2³¹-1 test pattern.

SFP+ Transceiver Electrical Pad Layout

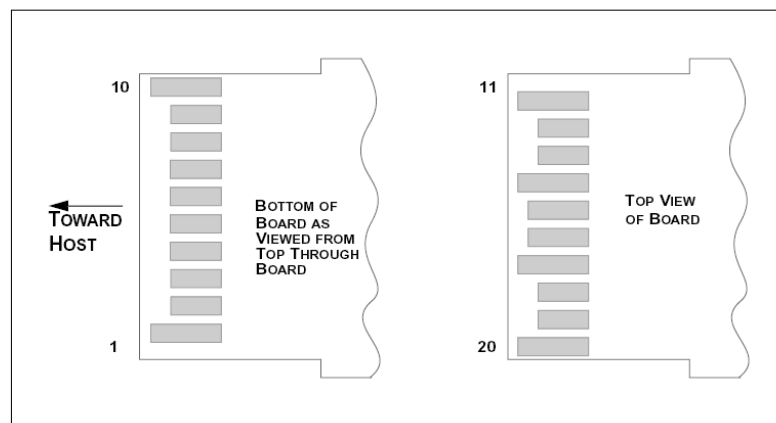
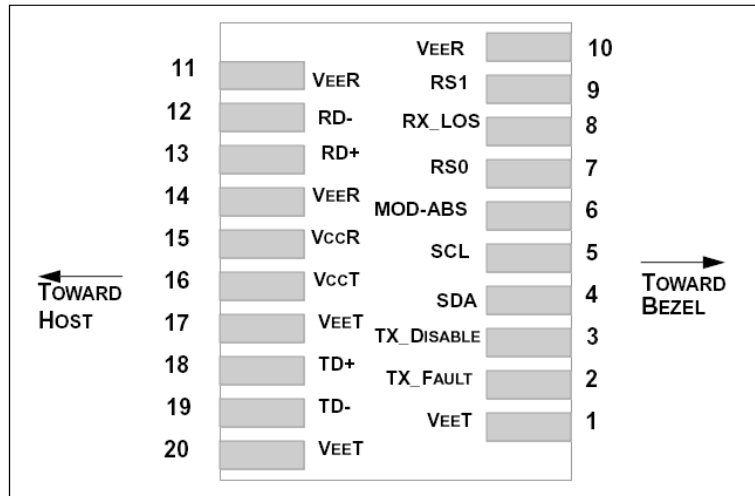

Pin Function Definitions

Pin Num.	Name	Function	Plug Seq.	Notes
1	VeeT	Transmitter Ground	1	Note 5
2	TX Fault	Transmitter Fault Indication	3	Note 1
3	TX Disable	Transmitter Disable	3	Note 2, Module disables on high or open
4	SDA	Module Definition 2	3	Data line for Serial ID.
5	SCL	Module Definition 1	3	Clock line for Serial ID.
6	MOD-ABS	Module Definition 0	3	Note 3
7	RS0	RX Rate Select (LVTTTL).	3	This pin has an internal 30k pull down to ground. A signal on this pin will not affect module performance.

8	LOS	Loss of Signal	3	Note 4
9	RS1	TX Rate Select (LVTTTL).	1	This pin has an internal 30k pull down to ground. A signal on this pin will not affect module performance.
10	VeeR	Receiver Ground	1	Note 5
11	VeeR	Receiver Ground	1	Note 5
12	RD-	Inv. Received Data Out	3	Note 6
13	RD+	Received Data Out	3	Note 6
14	VeeR	Receiver Ground	1	Note 5
15	VccR	Receiver Power	2	3.3V ± 5%, Note 7
16	VccT	Transmitter Power	2	3.3V ± 5%, Note 7
17	VeeT	Transmitter Ground	1	Note 5
18	TD+	Transmit Data In	3	Note 8
19	TD-	Inv. Transmit Data In	3	Note 8
20	VeeT	Transmitter Ground	1	Note 5

Notes:

1) TX Fault is an open collector/drain output, which should be pulled up with a 4.7K – 10KΩ resistor on the host board. Pull up voltage between 2.0V and VccT/R+0.3V. When high, output indicates a laser fault of some kind. Low indicates normal operation. In the low state, the output will be pulled to < 0.8V.

2) TX disable is an input that is used to shut down the transmitter optical output. It is pulled up within the module with a 4.7K~10 K Ω resistor. Its states are:

Low (0 – 0.8V): Transmitter on

(>0.8, < 2.0V): Undefined

High (2.0 – 3.465V): Transmitter Disabled

Open: Transmitter Disabled

3) Module Absent, connected to VeeT or VeeR in the module.

4) LOS (Loss of Signal) is an open collector/drain output, which should be pulled up with a 4.7K – 10KΩ resistor on host board. Pull up voltage between 2.0V and VccT/R+0.3V. When high, this output indicates the received optical power is below the worst-case receiver sensitivity (as defined by the standard in use). Low indicates normal operation. In the low state, the output will be pulled to < 0.8V.

5) VeeR and VeeT may be internally connected within the SFP+ module.

6) RD-/+ : These are the differential receiver outputs. They are AC coupled 100Ω differential lines which should be terminated with 100Ω (differential) at the user SERDES. The AC coupling is done inside the module and is thus not required on the host board. The voltage swing on these lines will be between 370 and 700 mV differential (185 –350mV single ended) when properly terminated.

7) VccR and VccT are the receiver and transmitter power supplies. They are defined as 3.3V $\pm 5\%$ at the SFP+ connector pin. Maximum supply current is 300mA. Recommended host board power supply filtering is shown below. Inductors with DC resistance of less than 1 ohm should be used in order to maintain the required voltage at the SFP+ input pin with 3.3V supply voltage. When the recommended supply-filtering network is used, hot plugging of the SFP+ transceiver module will result in an inrush current of no more than 30mA greater than the steady state value. VccR and VccT may be internally connected within the SFP+ transceiver module.

8) TD-/+: These are the differential transmitter inputs. They are AC-coupled, differential lines with 100 Ω differential termination inside the module. The AC coupling is done inside the module and is thus not required on the host board.

EEPROM

The serial interface uses the 2-wire serial CMOS EEPROM protocol defined for the ATMEL AT24C02/04 family of components. When the serial protocol is activated, the host generates the serial clock signal (SCL). The serial data signal (SDA) is bi-directional for serial data transfer. The host uses SDA in conjunction with SCL to mark the start and end of serial protocol activation. The memories are organized as a series of 8-bit data words that can be addressed individually or sequentially.

The Module provides diagnostic information about the present operating conditions. The transceiver generates this diagnostic data by digitization of internal analog signals. Calibration and alarm/warning threshold data is written during device manufacture. Received power monitoring, transmitted power monitoring, bias current monitoring, supply voltage monitoring and temperature monitoring all are implemented. If the module is defined as external calibrated, the diagnostic data are raw A/D values and must be converted to real world units using calibration constants stored in EEPROM locations 56 – 95 at wire serial bus address A2H. The digital diagnostic memory map specific data field define as following .For detail EEPROM information, please refer to the related document of SFF 8472 Rev 10.3.

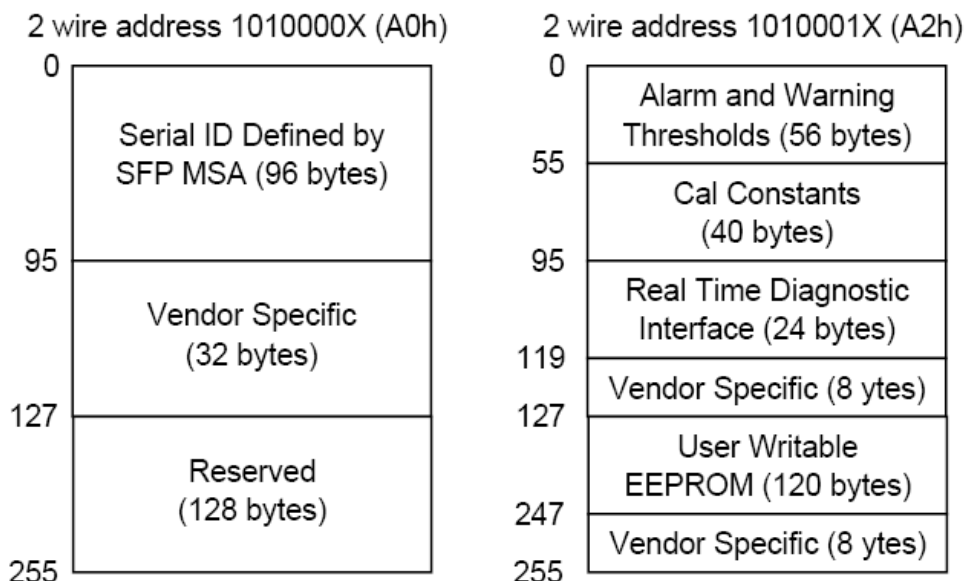

Recommend Circuit Schematic

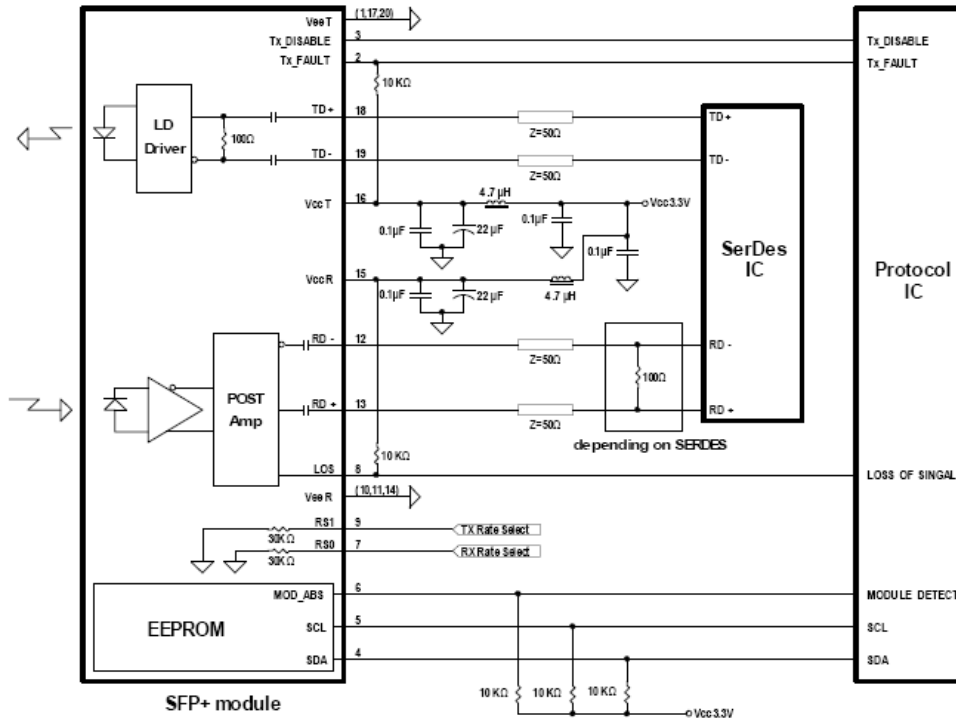

Mechanical Specifications

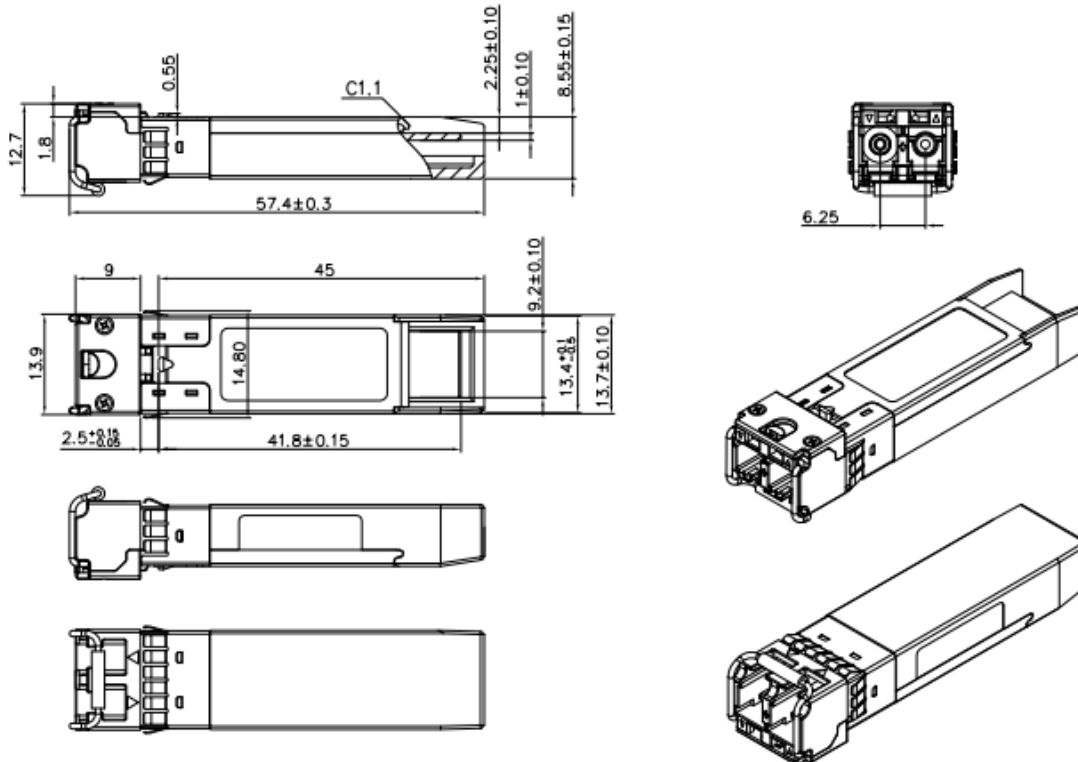

Unremarked tolerances ±0.2mm

Eye Safety

This single-mode transceiver is a Class 1 laser product. It complies with IEC-60825 and FDA 21 CFR 1040.10 and 1040.11. The transceiver must be operated within the specified temperature and voltage limits. The optical ports of the module shall be terminated with an optical connector or with a dust plug.

Obtaining Document

You can visit our website: <http://www.eoptolink.com>

Or contact Eoptolink Technology Inc., Ltd. Listed at the end of the documentation to get the latest documents.

Revision History

Revision	Initiate	Review	Approve	Revision History	Release Date
V1.a	Frank	Kelly		New released.	Mar 5, 2013
V1.b	Angela	Kelly/Vina		Update the regulatory compliance and mechanical spec.	Feb 03,2015
V1.c	Angela	Kelly/Vina		Add industrial temperature and CPRI/OBSAI application. Update the 2D drawing.	July 15, 2015

Notice:

Eoptolink reserves the right to make changes to or discontinue any optical link product or service identified in this publication, without notice, in order to improve design and/or performance. Applications that are described herein for any of the optical link products are for illustrative purposes only. Eoptolink makes no representation or warranty that such applications will be suitable for the specified use without further testing or modification.

Contact:

Add: Floor 5, Building 2, No. 21 Gaopeng Avenue, High-Tech District, CHENGDU, SICHUAN
610041 P.R. CHINA

Tel: (+86) 028-85122709 ext 808 & 809

Fax: (+86) 028-85121912

Postal: 610041

E-mail:sales@eoptolink.com

<http://www.eoptolink.com>