

## EOLP-1696-14X

**CWDM SFP+ Single-Mode for 10GbE**  
**Duplex SFP+ Transceiver**  
**RoHS6 Compliant**



### Features

- ◆ Up to 11.3Gb/s bit rates
- ◆ Hot-Pluggable SFP+ footprint
- ◆ 18-Wavelength CWDM DFB Transmitter from 1270nm to 1610nm, with step 20nm
- ◆ 14dB Power Budget
- ◆ Duplex LC connector
- ◆ Power Dissipation < 1.2W
- ◆ Case operation temperature range : -5°C to 70°C
- ◆ Compliant with SFP+ MSA Specification SFF-8431
- ◆ Build-in digital diagnostic functions
- ◆ Compliant with SFF-8472 MSA

### Applications

- ◆ 10GBASE-ER/EW 10G Ethernet
- ◆ 10GBASE-ER at 10.31Gbps
- ◆ 10GBASE-EW at 9.95Gbps
- ◆ OBSAI rates 6.144 Gb/s, 3.072 Gb/s, 1.536 Gb/s, 0.768Gb/s
- ◆ CPRI rates 10.138Gb/s,9.830 Gb/s, 7.373Gb/s, 6.144 Gb/s, 4.915 Gb/s, 2.458 Gb/s, 1.229 Gb/s, 0.614Gb/s
- ◆ Other optical links

### Ordering information

Part No.	Data Rate	Laser	Fiber	Power budget	Temp.	Interface
EOLP-1696-14X <sup>*(note1)</sup>	0.614Gbps to 11.3Gbps	CWDM DFB	SMF	>14dB	-5~70°C	LC

Note1: X refers to CWDM Wavelength range 1270nm to 1610nm, X=A~R, denote 1270nm to 1610nm.

\*The product image only for reference purpose.

**CWDM\* Wavelength**

Band	Nomenclature	Wavelength(nm)		
		Min.	Typ.	Max.
O-band Original	A	1264	1270	1277.5
	B	1284	1290	1297.5
	C	1304	1310	1317.5
	D	1324	1330	1337.5
	E	1344	1350	1357.5
E-band Extended	F	1364	1370	1377.5
	G	1384	1390	1397.5
	H	1404	1410	1417.5
	I	1424	1430	1437.5
	J	1444	1450	1457.5
S-band Short Wavelength	K	1464	1470	1477.5
	L	1484	1490	1497.5
	M	1504	1510	1517.5
	N	1524	1530	1537.5
C-band Conventional	O	1544	1550	1557.5
L-band Long Wavelength	P	1564	1570	1577.5
	Q	1584	1590	1597.5
	R	1604	1610	1617.5

CWDM\*: 18 Wavelengths from 1270nm to 1610nm, each step 20nm. Please contact EOPTOLINK to confirm whether the wavelength is available.

**Regulatory Compliance\*<sup>Note2</sup>**

Product Certificate	Certificate Number	Applicable Standard
TUV	R50135086	EN 60950-1:2006+A11+A1+A12+A2
		EN 60825-1:2014
		EN 60825-2:2004+A1+A2
UL	E317337	UL 60950-1
		CSA C22.2 No. 60950-1-07
EMC CE	AE 50285865 0001	EN 55022:2010
		EN 55024:2010
FCC	WTF14F0514417E	47 CFR PART 15 OCT., 2013
FDA	/	CDRH 1040.10
ROHS	/	2011/65/EU

Note2: The above certificate number updated to June 2014, because some certificate will be updated every year, such as FDA and ROHS. For the latest certification information, please check with Eoptolink.

## Product Description

The EOLP-1696-14X series optical transceiver is designed for fiber communications application such as 10G Ethernet (10GBASE-LR), which fully compliant with the specification of SFP+ MSA SFF-8431.

This module is designed for single mode fiber and operates at a nominal wavelength of CWDM wavelength. There are ten center wavelengths available from 1270nm to 1610nm, with each step 20nm. A guaranteed minimum optical link budget of 14 dB is offered.

The module is with the SFP+ connector to allow hot plug capability. Single 3.3V power supply is needed. The optical output can be disabled by LVTTTL logic high-level input of TX\_DIS. Loss of signal (RX\_LOS) output is provided to indicate the loss of an input optical signal of receiver.

This module provides digital diagnostic functions via a 2-wire serial interface as defined by the SFF-8472 specification.

## Absolute Maximum Ratings

Parameter	Symbol	Min	Typical	Max	Unit
Maximum Supply Voltage 1	V <sub>cc</sub>	-0.5		4.0	V
Storage Temperature	T <sub>s</sub>	-40		85	°C

## Recommend Operating Condition

Parameter	Symbol	Min	Typical	Max	Units
Operating Temperature	T <sub>c</sub>	-5		+70	°C
Supply Voltage	V <sub>cc</sub>	3.13	3.3	3.45	V
Supply Current	I <sub>cc</sub>			350	mA
Data Rate		0.614		11.3	Gbps

## Electrical Characteristics

Parameter	Symbol	Min.	Typ.	Max	Unit	Notes
<b>Transmitter</b>						
CML Inputs(Differential)	V <sub>in</sub>	150		1200	mVpp	1
Input Impedance (Differential)	Z <sub>in</sub>	85	100	115	ohm	
Tx_DISABLE Input Voltage – High		2		V <sub>cc</sub> +0.3	V	
Tx_DISABLE Input Voltage – Low		0		0.8	V	
Tx_FAULT Output Voltage – High		2		V <sub>cc</sub> +0.3	V	
Tx_FAULT Output Voltage – Low		0		0.5	V	
<b>Receiver</b>						
CML Outputs (Differential)	V <sub>out</sub>	350		700	mVpp	1
Output Impedance (Differential)	Z <sub>out</sub>	85	100	115	ohms	
Rx_LOS Output Voltage – High		2		V <sub>cc</sub> +0.3	V	
Rx_LOS Output Voltage – Low		0		0.8	V	
MOD_DEF ( 2:0 )	VoH	2.5			V	2

	VoL	0		0.5	V	
--	-----	---	--	-----	---	--

## Notes:

1. After internal AC coupling.
2. Reference the SFF-8472 MSA.

## Optical Characteristics

Parameter	Symbol	Min	Typical	Max	Unit	Note
<b>Transmitter</b>						
Output Opt. Pwr: 9/125 SMF	P <sub>out</sub>	-1		4	dBm	1
Optical Extinction Ratio	ER	3.5			dB	
Optical Wavelength	$\lambda$	$\lambda_c - 6$	$\lambda_c$	$\lambda_c + 7.5$	nm	2
-20dB Spectrum Width	$\Delta\lambda$			1	nm	
Side Mode Suppression Ratio	SMSR	30			dB	
Transmitter and Dispersion Penalty	TDP			2	dB	
Average Launch Power of OFF Transmitter	P <sub>OFF</sub>			-30	dBm	
<b>Receiver</b>						
Receiver Sensitivity @ 10.5Gb/s	P <sub>min</sub>			-15	dBm	3
Maximum Input Power	P <sub>max</sub>	+0.5			dBm	
Optical Center Wavelength	$\lambda$	1260		1620	nm	
Receiver Reflectance	R <sub>rf</sub>			-27	dB	
LOS De-Assert	LOS <sub>D</sub>			-16	dBm	
LOS Assert	LOS <sub>A</sub>	-28			dBm	
LOS Hysteresis		1			dB	

## Notes:

1. Output power is coupled into a 9/125 $\mu$ m SMF.
2. ITU-T G.694.2 CWDM wavelength from 1270nm to 1610nm, each step 20nm.
3. Average received power; BER less than 1E-12 and PRBS 2<sup>31</sup>-1 test pattern.

## SFP+ Transceiver Electrical Pad Layout

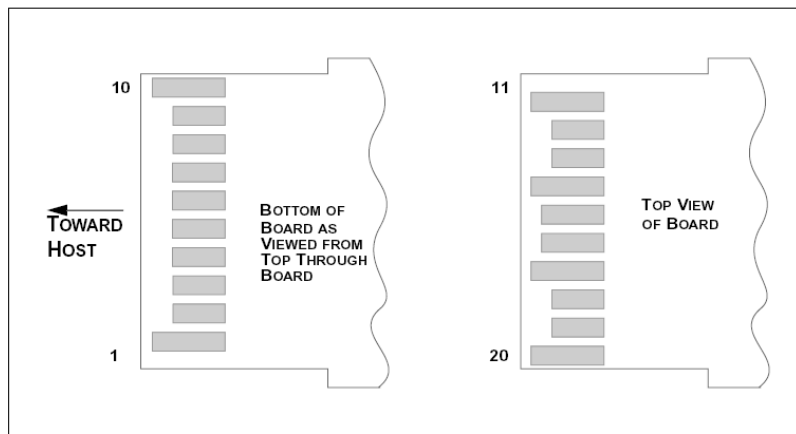
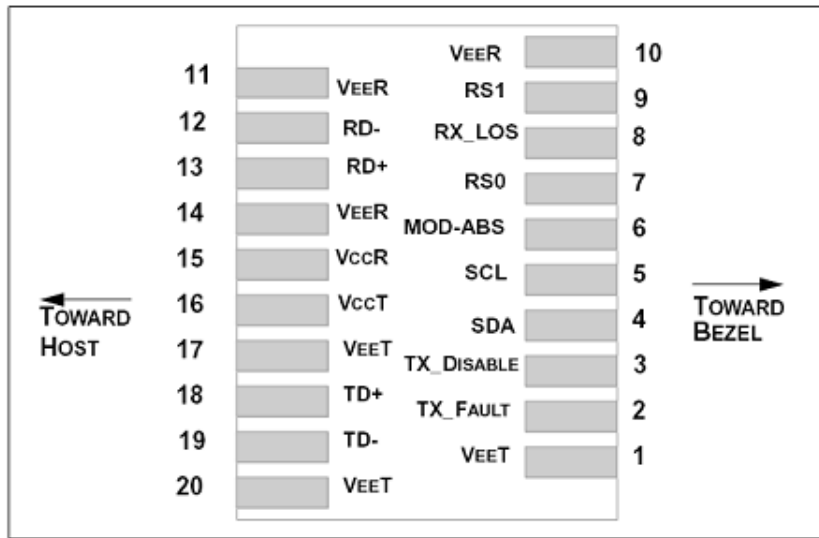

### Pin Function Definitions

Pin Num.	Name	Function	Plug Seq.	Notes
1	VeeT	Transmitter Ground	1	Note 5
2	TX Fault	Transmitter Fault Indication	3	Note 1
3	TX Disable	Transmitter Disable	3	Note 2, Module disables on high or open
4	SDA	Module Definition 2	3	Data line for Serial ID.
5	SCL	Module Definition 1	3	Clock line for Serial ID.
6	MOD-ABS	Module Definition 0	3	Note 3
7	RS0	RX Rate Select (LVTTTL).	3	No Function Implement.
8	LOS	Loss of Signal	3	Note 4
9	RS1	TX Rate Select (LVTTTL).	1	No Function Implement.

10	VeeR	Receiver Ground	1	Note 5
11	VeeR	Receiver Ground	1	Note 5
12	RD-	Inv. Received Data Out	3	Note 6
13	RD+	Received Data Out	3	Note 6
14	VeeR	Receiver Ground	1	Note 5
15	VccR	Receiver Power	2	3.3V ± 5%, Note 7
16	VccT	Transmitter Power	2	3.3V ± 5%, Note 7
17	VeeT	Transmitter Ground	1	Note 5
18	TD+	Transmit Data In	3	Note 8
19	TD-	Inv. Transmit Data In	3	Note 8
20	VeeT	Transmitter Ground	1	Note 5

### Notes:

- 1) TX Fault is an open collector/drain output, which should be pulled up with a 4.7K – 10KΩ resistor on the host board. Pull up voltage between 2.0V and VccT/R+0.3V. When high, output indicates a laser fault of some kind. Low indicates normal operation. In the low state, the output will be pulled to < 0.8V.
- 2) TX disable is an input that is used to shut down the transmitter optical output. It is pulled up within the module with a 4.7K~10 K Ω resistor. Its states are:  
 Low (0 – 0.8V): Transmitter on  
 (>0.8, < 2.0V): Undefined  
 High (2.0 – 3.465V): Transmitter Disabled  
 Open: Transmitter Disabled
- 3) Module absent, connected to VeeT or VeeR in the module.
- 4) LOS (Loss of Signal) is an open collector/drain output, which should be pulled up with a 4.7K – 10KΩ resistor. Pull up voltage between 2.0V and VccT/R+0.3V. When high, this output indicates the received optical power is below the worst-case receiver sensitivity (as defined by the standard in use). Low indicates normal operation. In the low state, the output will be pulled to < 0.8V.
- 5) VeeR and VeeT may be internally connected within the SFP+ module.
- 6) RD-/+ : These are the differential receiver outputs. They are AC coupled 100Ω differential lines which should be terminated with 100Ω (differential) at the user SERDES. The AC coupling is done inside the module and is thus not required on the host board. The voltage swing on these lines will be between 370 and 700 mV differential (185 –350 mV single ended) when properly terminated.
- 7) VccR and VccT are the receiver and transmitter power supplies. They are defined as 3.3V ±5% at the SFP+ connector pin. Maximum supply current is 350mA. Recommended host board power supply filtering is shown below. Inductors with DC resistance of less than 1 ohm should be used in order to maintain the required voltage at the SFP+ input pin with 3.3V supply voltage. When the recommended supply-filtering network is used, hot plugging of the SFP+ transceiver

module will result in an inrush current of no more than 30mA greater than the steady state value. VccR and VccT may be internally connected within the SFP+ transceiver module.

8) TD-/+: These are the differential transmitter inputs. They are AC-coupled, differential lines with 100Ω differential termination inside the module. The AC coupling is done inside the module and is thus not required on the host board. The inputs will accept differential swings of 150 – 1200 mV (75 – 600mV single-ended), though it is recommended that values between 150 and 1200 mV differential (75 – 600mV single-ended) be used for best EMI performance.

## EEPROM

The serial interface uses the 2-wire serial CMOS EEPROM protocol defined for the ATMEL AT24C02/04 family of components. When the serial protocol is activated, the host generates the serial clock signal (SCL). The positive edge clocks data into those segments of the EEPROM that are not writing protected within the SFP+ transceiver. The negative edge clocks data from the SFP+ transceiver. The serial data signal (SDA) is bi-directional for serial data transfer. The host uses SDA in conjunction with SCL to mark the start and end of serial protocol activation. The memories are organized as a series of 8-bit data words that can be addressed individually or sequentially.

The Module provides diagnostic information about the present operating conditions. The transceiver generates this diagnostic data by digitization of internal analog signals. Calibration and alarm/warning threshold data is written during device manufacture. Received power monitoring, transmitted power monitoring, bias current monitoring, supply voltage monitoring and temperature monitoring all are implemented. If the module is defined as external calibrated, the diagnostic data are raw A/D values and must be converted to real world units using calibration constants stored in EEPROM locations 56 – 95 at wire serial bus address A2H. The digital diagnostic memory map specific data field define as following .For detail EEPROM information, please refer to the related document of SFF 8472 Rev 10.3.

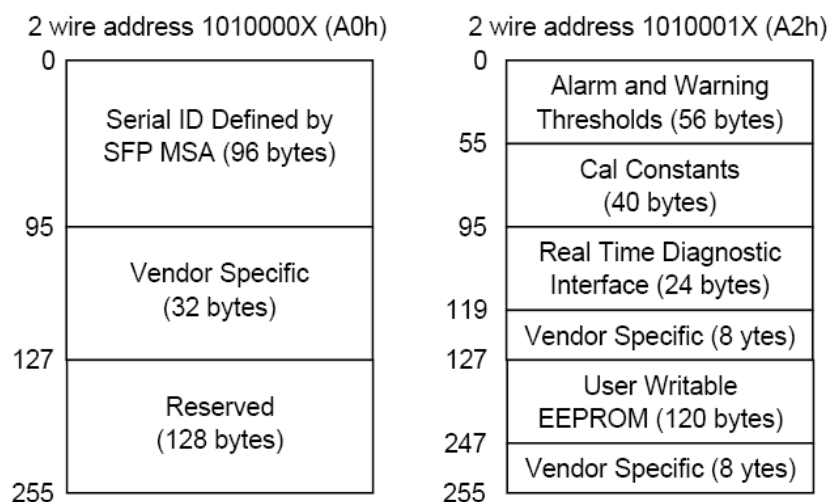

## EEPROM Serial ID Memory Contents

Accessing Serial ID Memory uses the 2 wire address 1010000X (A0h). Memory Contents of Serial ID are shown in Table 1.

**Table 1 Serial ID Memory Contents**

Addr.	Size (Bytes)	Name of Field	Hex	Description
<b>BASE ID FIELDS</b>				
0	1	Identifier	03	SFP
1	1	Ext. Identifier	04	SFP function is defined by serial ID only
2	1	Connector	07	LC Connector
3-10	8	Transceiver	20 00 00 00 00 00 00 00	Transmitter Code
11	1	Encoding	01	8B10B
12	1	BR, Nominal	6B	10.7Gbps
13	1	Reserved	00	
14	1	Length (9μm)km	1E	Transceiver transmit distance
15	1	Length(9μm)100m	FF	
16	1	Length (50μm) 10m	00	
17	1	Length(62.5μm)10m	00	
18	1	Length (Copper)	00	Not compliant
19	1	Reserved	00	
20-35	16	Vendor name	XX XX XX XX XX XX XX XX XX XX XX XX XX XX XX XX XX	(ASCII)
36	1	Reserved	00	
37-39	3	Vendor OUI	00 53 4F	00 83 79(DEC)
40-55	16	Vendor PN	XX XX XX XX XX XX XX XX XX XX XX XX XX XX XX XX <sup>(Note2)</sup>	PN
56-59	4	Vendor rev	XX XX XX XX <sup>(Note2)</sup>	ASCII (31 2E 30 20means 1.0 revision)
60-61	2	Wavelength	XX XX <sup>(Note2)</sup>	XX
62	1	Reserved	00	
63	1	CC_BASE	Check Sum (Variable)	Check code for Base ID Fields
<b>EXTENDED ID FIELDS</b>				
64-65	2	Options	00 1A	TX_DISABLE, TX_FAULT and Rx_LOS implemented.
66	1	BR,max	00	
67	1	BR,min	00	
68-83	16	Vendor SN	XX XX XX XX XX XX XX XX 20 20 20 20 20 20	Serial Number of transceiver (ASCII). For example



			20 <sup>(Note2)</sup>	"B000822".
84-91	8	Date code	XX XX XX XX XX XX XX XX <sup>(Note2)</sup>	Manufacture date code. For example "080405".
92	1	Diagnostic Monitoring Type	68	Digital diagnostic monitoring implemented; Internally calibrated; average power
93	1	Enhanced Options	B2	Optional Alarm/warning flags implemented; Optional soft TX_FAULT and RX_LOS monitoring implemented. Optional Rate Select control implemented per SFF-8431.
94	1	SFF-8472 Compliance	03	03 for Rev10.2 SFF-8472.
95	1	CC_EXT	Check Sum (Variable)	Check sum for Extended ID Field.
<b>VENDOR SPECIFIC ID FIELDS</b>				
96-127	32	Vendor Specific	Read only	Depends on customer information
128-255	128	Reserved	Read only	

Note2: The "XX" byte should be filled in according to practical case. For more information, please refer to the related document of SFP Multi-Source Agreement (MSA).

### Digital Diagnostic Specifications

EOLP-1696-14X transceivers can be used in host systems that require either internally or externally calibrated digital diagnostics.

Parameter	Symbol	Accuracy	Units	Ref.
Internally measured transceiver temperature	DD Temperature	±3	°C	
Internally measured transceiver supply voltage	DD Voltage	±3	%	
Measured TX bias current	DD Bias	±10	%	Note3
Measured TX output power	DD Tx-Power	±2	dB	
Measured RX received average optical power	DD Rx-Power	±2	dB	

Note3. Accuracy of Measured Tx Bias Current is 10% of the actual Bias Current from the laser driver to the laser.

Recommend Circuit Schematic

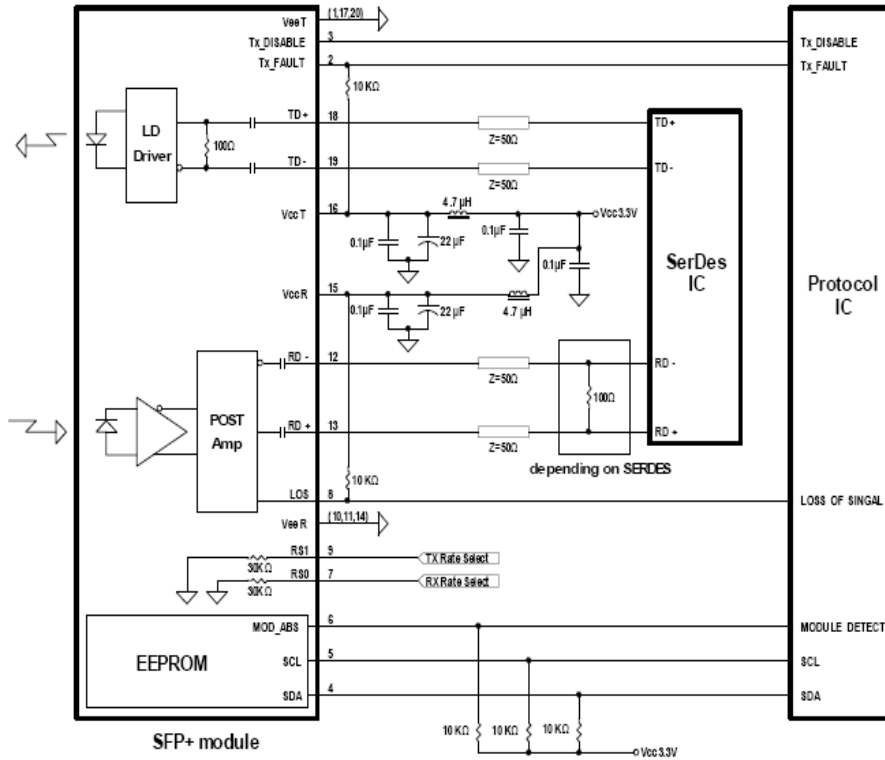

Mechanical Specifications

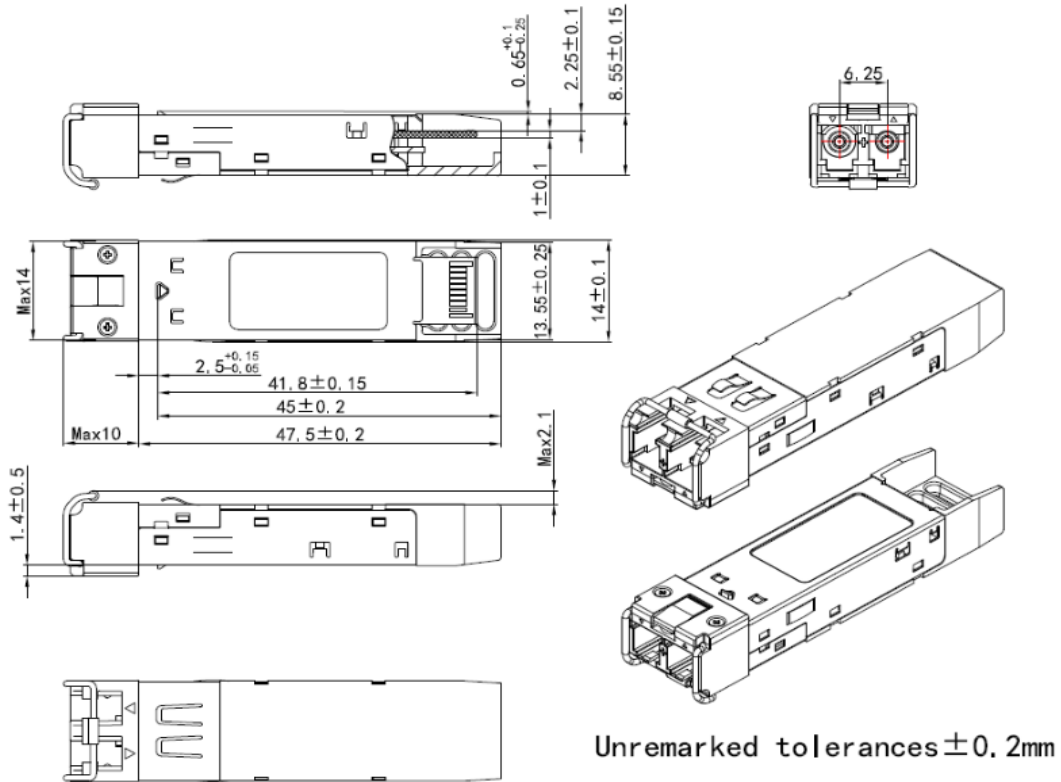

\*This 2D drawing only for reference, please check with Eoptolink before ordering.

## Eye Safety

This single-mode transceiver is a Class 1 laser product. It complies with IEC-60825 and FDA 21 CFR 1040.10 and 1040.11. The transceiver must be operated within the specified temperature and voltage limits. The optical ports of the module shall be terminated with an optical connector or with a dust plug.

## Obtaining Document

You can visit our website: <http://www.eoptolink.com>

Or contact Eoptolink Technology Inc., Ltd. Listed at the end of the documentation to get the latest documents.

## Revision History

Revision	Initiate	Review	Approve	DCN	Release Date
V3.a	Kelly			Update PN.	June 13, 2011
V4.0	Alex/Townie	Kelly		Update spelling mistake	Aug 10, 2011
V4.a	Townie	Kelly		Add power dissipation.	Aug 23, 2011
V4.b	Frank/ JP.jiang	Kelly/Fing		Update Po & SEN	Mar 14,2013
V4.c	Angela	Fing/Frank/ Jason/Walt/Lyn		Update wavelength range and regulatory compliance	Feb 12,2014
V4.d	Abby	Kelly/Vina		Update Mechanical Specifications	Feb 3, 2015
V4.e	Angela	Kelly/Fing/Vina		Add CPRI/OBSAI application. Update the max data rate and 2D drawing.	July 7,2015
V4.f	Angela	Fing/JP/Eason		Update the bit rates.	Oct 21,2015
V4.g	Angela	Kelly/Vina/Dean /Chao.Wang		Update the CPRI data rates, regulatory compliance and the 2D drawing.	Nov 24,2016
V4.h	Angela	Kelly/Marvin/Carol		Update the CWDM	Dec 14,2016

				wavelength range from 1270~1450nm to 1270~1610nm.	
V4.i	Elaine	Kelly/Angela/Marvin/ Torres/Sky William/Chao.Wang		Update the RS0/RS1 Pin function definition notes, the picture, 2D drawing and the contact.	Mar 23, 2018

### Notice:

Eoptolink reserves the right to make changes to or discontinue any optical link product or service identified in this publication, without notice, in order to improve design and/or performance. Applications that are described herein for any of the optical link products are for illustrative purposes only. Eoptolink makes no representation or warranty that such applications will be suitable for the specified use without further testing or modification.

### Contact:

Add: No.127 West Wulian Street, Gongxing Town, Shuangliu district, Chengdu City, Sichuan, China.

Tel: (+86) 028-67087999

Fax: (+86) 28-67087979-8010

Postal: 610213

E-mail: sales@eoptolink.com

<http://www.eoptolink.com>