

EOLP-1660-10X

CWDM SFP+ Single-Mode
Multi Rate 600Mbps~6.25Gbps
Duplex SFP+ Transceiver
RoHS 6 Compliant



Features

- ◆ Operating data rate up to 6.25Gbps
- ◆ CWDM DFB-LD Transmitter
- ◆ Power Budget 10dB at least
- ◆ 2-wire interface for digital diagnostic monitoring
- ◆ Single 3.3V Power supply and TTL Logic Interface
- ◆ Duplex LC Connector Interface
- ◆ Hot Pluggable
- ◆ Operating Case Temperature
Standard: -5°C~+70°C
- ◆ Compliant with SFF-8431 and 8472
- ◆ Compliant with FC standard INCITS 352

Applications

- ◆ High speed storage area networks
- ◆ OBSAI interface, such as
6.144/1.536/3.072/1.536Gbps and
768Mbps
- ◆ CPRI interface, such as
6.144/3.072/2.4576/1.228Gbps and
614Mbps
- ◆ Other Optical Network

Ordering information

Part No.	Data Rate	Laser	Fiber Type	Power Budget	Temperature	DDMI
EOLP-1660-10X* note1	0.614Gbps to 6.25Gbps	CWDM DFB	SMF	≥10dB	Standard	YES

Note1: Standard version. X indicates the CWDM wavelength, applying A~R denotes 1270nm~1610nm. Further information, please refer the following table.

CWDM* Wavelength

Band	Nomenclature	Wavelength(nm)		
		Min.	Typ.	Max.
O-band Original	A	1264.5	1271	1277.5
	B	1284.5	1291	1297.5
	C	1304.5	1311	1317.5
	D	1324.5	1331	1337.5
	E	1344.5	1351	1357.5
E-band Extended	F	1364.5	1371	1377.5
	G	1384.5	1391	1397.5
	H	1404.5	1411	1417.5
	I	1424.5	1431	1437.5
	J	1444.5	1451	1457.5
S-band Short Wavelength	K	1464.5	1471	1477.5
	L	1484.5	1491	1497.5
	M	1504.5	1511	1517.5
	N	1524.5	1531	1537.5
C-band Conventional	O	1544.5	1551	1557.5
L-band Long Wavelength	P	1564.5	1571	1577.5
	Q	1584.5	1591	1597.5
	R	1604.5	1611	1617.5

Note2: Please contact EOPTOLINK to confirm whether the wavelength is available.

Regulatory Compliance*

Product Certificate	Certificate Number	Applicable Standard
TUV	R50135086	EN 60950-1:2006+A11+A1+A12
		EN 60825-1:2007
		EN 60825-2:2004+A1+A2
UL	E317337	UL 60950-1
		CSA C22.2 No. 60950-1-07
EMC CE	AE 50285865 0001	EN 55022:2010
		EN 55024:2010
CB	JPTUV-049251	IEC 60825-1
		IEC 60950-1
FCC	WTF14F0514437E	47 CFR PART 15 OCT., 2013
FDA	1331340-000	CDRH 1040.10
ROHS	RHS01G006464	2011/65/EU

*The above certificate number updated to June 2014, because some certificate will be updated every year, such as FCC, FDA and ROHS. For the latest certification information, please check with Eoptolink.

Product Description

This module is designed for single mode fiber and operates at CWDM wavelength. The transmitter section uses a CWDM DFB laser and is a class 1 laser compliant according to International Safety Standard IEC-60825.

The receiver section uses an integrated InGaAs PIN detector preamplifier (IDP) mounted in an optical header and a limiting post-amplifier IC.

Absolute Maximum Ratings

Parameter	Symbol	Min.	Max.	Unit
Storage Temperature	T _s	-40	+85	°C
Supply Voltage	V _{CC}	-0.5	3.6	V

Recommended Operating Conditions

Parameter	Symbol	Min.	Typical	Max.	Unit
Operating Case Temperature	T _c EOLP-1660-10X	-5		+70	°C
Power Supply Voltage	V _{CC}	3.15	3.3	3.45	V
Power Supply Current	I _{CC}			300	mA
Surge Current	I _{Surge}			+30	mA
Data Rate		0.614		6.25	Gbps

Performance Specifications - Electrical

Parameter	Symbol	Min.	Typ.	Max	Unit	Notes
Transmitter						
CML Inputs(Differential)	V _{in}	150		1200	mVpp	AC coupled inputs
Input Impedance (Differential)	Z _{in}	85	100	115	ohm	R _{in} > 100 kohms @ DC
Tx_DISABLE Input Voltage - High		2.0		3.45	V	
Tx_DISABLE Input Voltage - Low		0		0.8	V	
Tx_FAULT Output Voltage -- High		2.0		V _{CC} +0.3	V	I _o = 400μA; Host V _{CC}
Tx_FAULT Output Voltage -- Low		0		0.5	V	I _o = -4.0mA
Receiver						
CML Outputs (Differential)	V _{out}	350		700	mVpp	AC coupled outputs
Output Impedance (Differential)	Z _{out}	85	100	115	ohm	
Rx_LOS Output Voltage - High		2.0		V _{CC} +0.3	V	I _o = 400μA; Host V _{CC}
Rx_LOS Output Voltage - Low		0		0.8	V	I _o = -4.0mA
MOD_DEF (2:0)	VoH	2.5			V	With Serial ID
	VoL	0		0.5	V	

Performance Specifications - Optical

Parameter	Symbol	Min.	Typical	Max.	Unit
Power Budget		10			dB
Data Rate		0.614		6.25	Gbps
Transmitter					
Center Wavelength	λ_C	$\lambda_C - 6.5$	λ_C	$\lambda_C + 6.5$	nm
Spectral Width (-20dB)	$\Delta\lambda$			1	nm
Average Output Power	P_{out}	-5		0	dBm
Extinction Ratio	ER	4.5	6		dB
Average Power of OFF Transmitter	P_{off}			-30	dBm
Input Differential Impedance	Z_{IN}	90	100	110	Ω
TX Disable Assert Time	t_{off}			10	Us
Receiver					
Centre Wavelength	λ	1260		1620	Nm
Sensitivity @ 6.25Gbps	P_{min}			-15	dBm
Receiver Overload	P_{max}	-1			dBm
Optical Return Loss	ORL			-12	dB
LOS De-Assert	LOS_D			-16	dBm
LOS Assert	LOS_A	-30			dBm
LOS Hysteresis	LOS_H	0.5			dB
Output Differential Impedance	Z_{OUT}	90	100	110	Ω
LOS	High		2.0	$V_{CC} + 0.3$	V
	Low		0	0.8	

SFP+ Transceiver Electrical Pad Layout

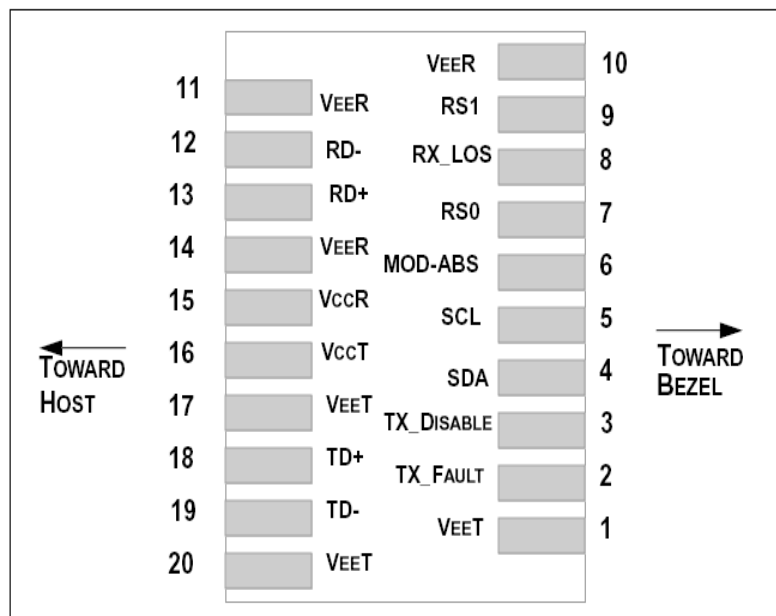

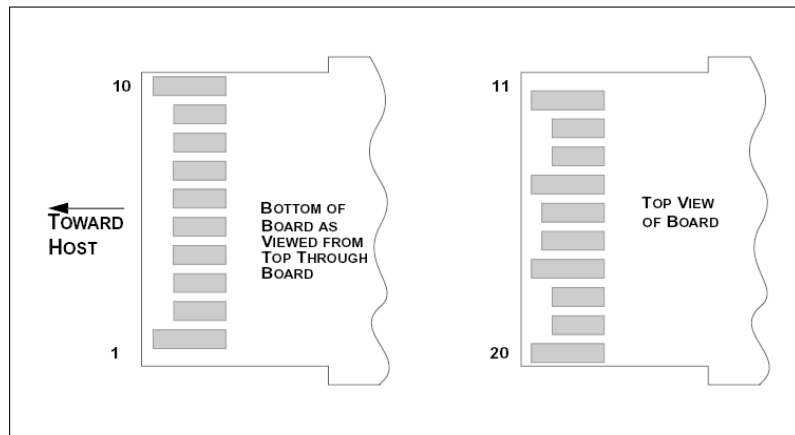

Pin Function Definitions

Pin Num.	Name	FUNCTION	Plug Seq.	Notes
1	VeeT	Transmitter Ground	1	Note 5
2	TX Fault	Transmitter Fault Indication	3	Note 1
3	TX Disable	Transmitter Disable	3	Note 2, Module disables on high or open
4	SDA	Module Definition 2	3	2-wire Serial Interface Data Line.
5	SCL	Module Definition 1	3	2-wire Serial Interface Clock.
6	MOD-ABS	Module Definition 0	3	Note 3
7	RS0	RX Rate Select (LVTTTL).	3	Rate Select 0, optionally controls SFP+ module receiver. This pin is pulled low to VeeT with a >30K resistor..
8	LOS	Loss of Signal	3	Note 4
9	RS1	TX Rate Select (LVTTTL).	1	Rate Select 1, optionally controls SFP+ module transmitter. This pin is pulled low to VeeT with a >30K resistor.
10	VeeR	Receiver Ground	1	Note 5
11	VeeR	Receiver Ground	1	Note 5
12	RD-	Inv. Received Data Out	3	Note 6
13	RD+	Received Data Out	3	Note 7
14	VeeR	Receiver Ground	1	Note 5
15	VccR	Receiver Power	2	3.3V ± 5%, Note 7
16	VccT	Transmitter Power	2	3.3V ± 5%, Note 7
17	VeeT	Transmitter Ground	1	Note 5
18	TD+	Transmit Data In	3	Note 8
19	TD-	Inv. Transmit Data In	3	Note 8
20	VeeT	Transmitter Ground	1	Note 5

Notes:

- 1) TX Fault is an open collector/drain output, which should be pulled up with a 4.7K – 10KΩ resistor on the host board. Pull up voltage between 2.0V and $V_{ccT}/R+0.3V$. When high, output indicates a laser fault of some kind. Low indicates normal operation. In the low state, the output will be pulled to $< 0.8V$.
- 2) TX disable is an input that is used to shut down the transmitter optical output. It is pulled up within the module with a 4.7K – 10 KΩ resistor. Its states are:
Low (0 – 0.8V): Transmitter on
($>0.8, < 2.0V$): Undefined
High (2.0 – 3.465V): Transmitter Disabled
Open: Transmitter Disabled
- 3) Module Absent, connected to VeeT or VeeR in the module.
- 4) LOS (Loss of Signal) is an open collector/drain output, which should be pulled up with a 4.7K – 10KΩ resistor. Pull up voltage between 2.0V and $V_{ccT}/R+0.3V$. When high, this output indicates the received optical power is below the worst-case receiver sensitivity (as defined by the standard in use). Low indicates normal operation. In the low state, the output will be pulled to $< 0.8V$.
- 5) The module signal ground contacts, VeeR and VeeT, should be isolated from the module case.
- 6) RD-/+ : These are the differential receiver outputs. They are AC coupled 100Ω differential lines which should be terminated with 100Ω (differential) at the user SERDES. The AC coupling is done inside the module and is thus not required on the host board.
- 7) VccR and VccT are the receiver and transmitter power supplies. They are defined as 3.3V $\pm 5\%$ at the SFP+ connector pin. Maximum supply current is 300mA. Recommended host board power supply filtering is shown below. Inductors with DC resistance of less than 1 ohm should be used in order to maintain the required voltage at the SFP+ input pin with 3.3V supply voltage. When the recommended supply-filtering network is used, hot plugging of the SFP+ transceiver module will result in an inrush current of no more than 30mA greater than the steady state value. VccR and VccT may be internally connected within the SFP+ transceiver module.
- 8) TD-/+ : These are the differential transmitter inputs. They are AC-coupled, differential lines with 100Ω differential termination inside the module. The AC coupling is done inside the module and is thus not required on the host board.

EEPROM

The serial interface uses the 2-wire serial CMOS EEPROM protocol defined for the ATMEL AT24C02/04 family of components. When the serial protocol is activated, the host generates the serial clock signal (SCL). The positive edge clocks data into those segments of the EEPROM that are not writing protected within the SFP+ transceiver. The negative edge clocks data from the SFP+ transceiver. The serial data signal (SDA) is bi-directional for serial data transfer. The host uses SDA in conjunction with SCL to mark the start and end of serial protocol activation. The memories are organized as a series of 8-bit data words that can be addressed individually or

sequentially.

The Module provides diagnostic information about the present operating conditions. The transceiver generates this diagnostic data by digitization of internal analog signals. Calibration and alarm/warning threshold data is written during device manufacture. Received power monitoring, transmitted power monitoring, bias current monitoring, supply voltage monitoring and temperature monitoring all are implemented. If the module is defined as external calibrated, the diagnostic data are raw A/D values and must be converted to real world units using calibration constants stored in EEPROM locations 56 – 95 at wire serial bus address A2h. The digital diagnostic memory map specific data field define as following .For detail EEPROM information, please refer to the related document of SFF 8472 Rev 10.2.

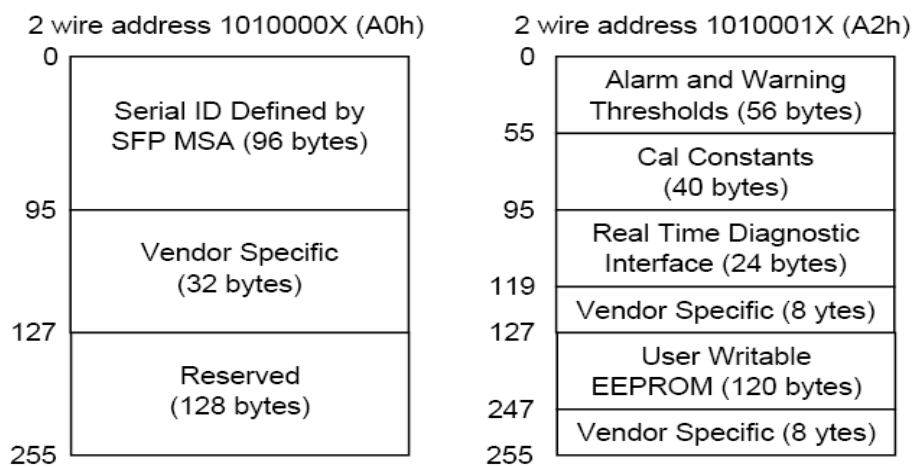

EEPROM Serial ID Memory Contents

Accessing Serial ID Memory uses the 2 wire address 1010000X (A0H). Memory Contents of Serial ID are shown in Table 1.

Table 1 Serial ID Memory Contents

Addr.	Size (Bytes)	Name of Field	Hex	Description
BASE ID FIELDS				
0	1	Identifier	03	SFP
1	1	Ext. Identifier	04	SFP function is defined by serial ID only
2	1	Connector	07	LC Connector
3-10	8	Transceiver	00 00 00 00 00 00 00 00	Undefined
11	1	Encoding	01	8B/10B
12	1	BR, Nominal	3F	6250Mbps
13	1	Reserved	00	
14	1	Length (9µm)km	0F	Transceiver transmit distance
15	1	Length(9µm)100m	96	

16	1	Length (50µm) 10m	00	
17	1	Length(62.5µm)10m	00	
18	1	Length (Copper)	00	
19	1	Reserved	00	
20-35	16	Vendor name	45 4F 50 54 4F 4C 49 4E 4B 20 20 20 20 20 20 20	ELOPTOLINK
36	1	Reserved	00	
37-39	3	Vendor OUI	XX XX XX ^(Note3)	
40-55	16	Vendor PN	45 4F 4C 50 2D 31 36 36 30 2D 31 30 XX 20 20 20	EOLP-1660-10X
56-59	4	Vendor rev	31 2E 30 20	1.0
60-61	2	Wavelength	XX XX	CWDM wavelength
62	1	Reserved	00	
63	1	CC_BASE	Check Sum (Variable)	Check code for Base ID Fields
EXTENDED ID FIELDS				
64-65	2	Options	00 1A	TX_DISABLE, TX_FAULT and Loss of Signal implemented.
66	1	BR,max	00	
67	1	BR,min	00	
68-83	16	Vendor SN	XX XX XX XX XX XX XX XX 20 20 20 20 20 20 20 20 ^(Note3)	Serial Number of transceiver (ASCII). For example "B000822".
84-91	8	Date code	XX XX XX XX XX XX XX XX ^(Note3)	Manufactory date code. For example "080405".
92	1	Diagnostic Monitoring Type	XX ^(Note3)	Digital diagnostic monitoring implemented
93	1	Enhanced Options	XX ^(Note3)	Optional flags
94	1	SFF_8472 Compliance	XX ^(Note3)	01 for diagnostics (Rev9.3 SFF-8472).
95	1	CC_EXT	Check Sum (Variable)	Check sum for Extended ID Field.
VENDOR SPECIFIC ID FIELDS				
96-127	32	Vendor Specific	Read only	Depends on customer information
128-255	128	Reserved	Read only	

Note3: The "XX" byte should be filled in according to practical case. For more information, please refer to the related document of SFP Multi-Source Agreement (MSA).

Recommend Circuit Schematic

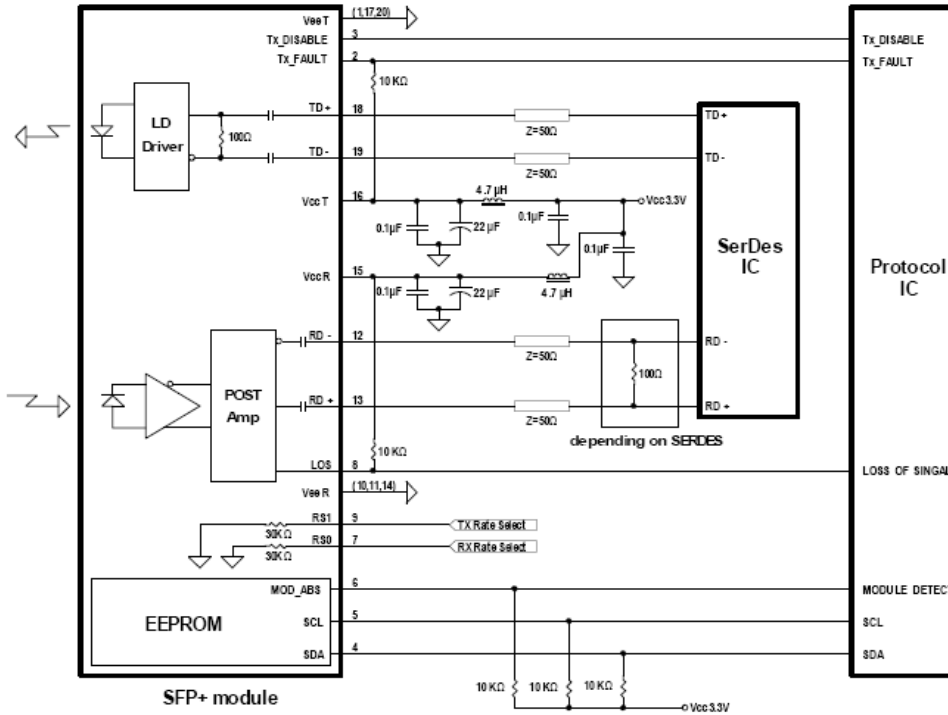

Mechanical Specifications

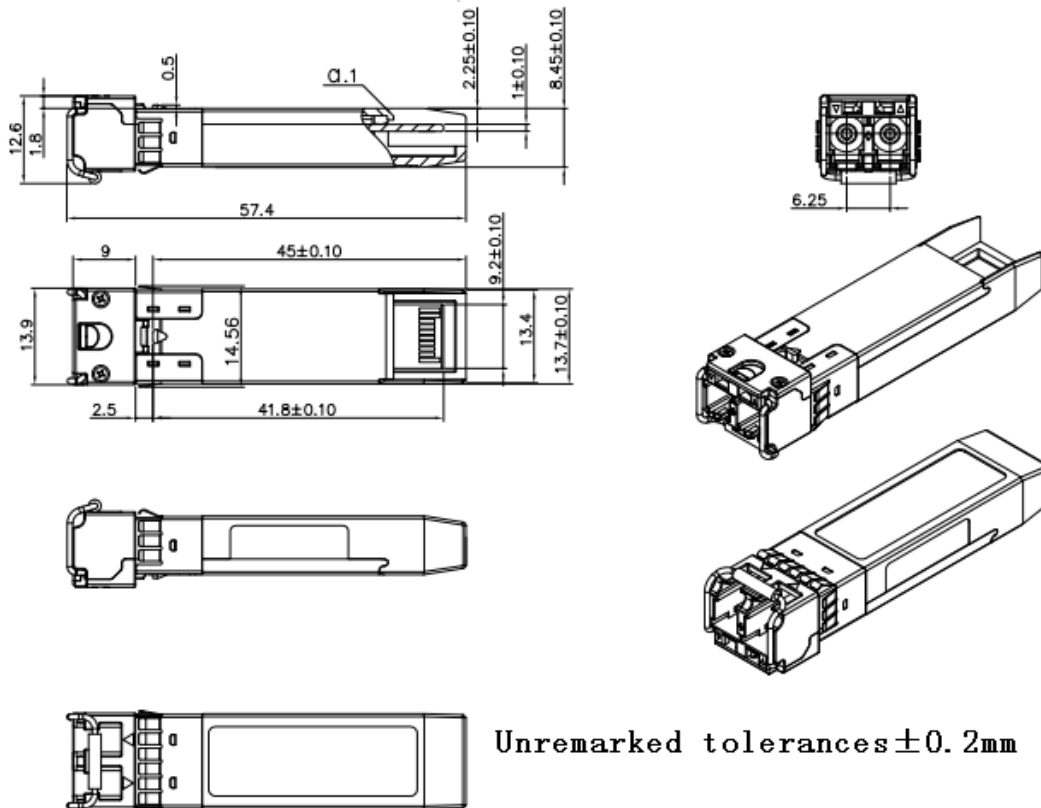

Eye Safety

This single-mode transceiver is a Class 1 laser product. It complies with IEC-60825 and FDA 21 CFR 1040.10 and 1040.11. The transceiver must be operated within the specified temperature and voltage limits. The optical ports of the module shall be terminated with an optical connector or with a dust plug.

Obtaining Document

You can visit our website: <http://www.eoptolink.com>

Or contact Eoptolink Technology Inc., Ltd. listed at the end of the documentation to get the latest document.

Revision History

Revision	Initiated	Reviewed	Approved	DCN	Release Date
V1.a	Kelly.Cao			Preliminary Released.	June 10, 2011
V2.0	Alex/Townie	Kelly		Update spelling mistakes	Aug 10, 2011
V2.a	Kelly			Update photo.	Oct 27, 2011
V2.b	Angela	Kelly		Update LOSA and pin definition notes.	Feb 6, 2013
V2.c	Abby	Kelly/JP.Jiang	Richard	Update ER and Regulatory Compliance	Oct 18, 2013
V2.d	Angela	Kelly		Update the regulatory compliance and 2D drawing.	July 6, 2015

Notice:

Eoptolink reserves the right to make changes to or discontinue any optical link product or service identified in this publication, without notice, in order to improve design and/or performance. Applications that are described herein for any of the optical link products are for illustrative purposes only. Eoptolink makes no representation or warranty that such applications will be suitable for the specified use without further testing or modification.

Contact:

Add: Floor 5 Building 2 No. 21 Gaopeng Avenue High-Tech District CHENGDU, SICHUAN 610041
P.R. CHINA

Tel: (+86) 028-85122709 ext 808 & 809

Fax: (+86) 028-85121912

Postal: 610041

E-mail: sales@eoptolink.com

<http://www.eoptolink.com>